

SECTIONAL ELEVATION

NOTE: THIS DRAWING SUPERCEDES THE EARLIER APPROVED DRAWING FOR 60KL OHSR ON Dt: 17.04.2017

NOTES

1. Grade of Concrete : M30
2. Grade of Steel : Fe500
3. Clear minimum cover
 - a) Water face:
 - Side walls : 45MM
 - Top & Bottom slabs : 45MM
 - Beams : 45MM
 - b) Away from Water face:
 - Side walls : 30MM
 - Top & Bottom slabs : 30MM
 - Beams : 30MM
 - c) Columns : 40MM
 - d) Footings : 50MM

4. All dimension are in 'mm' unless specified.
5. The steel should not be overlapped at the junction points
6. Not more than 1/2 of the bars should be curtailed at a given section
7. Suitable PVC pipe casing has to be Provided in the staircase column up to the top, for installation of lightning Arrester.
8. Seismic Zone : II
9. Wind speed : 44 m/s (Wind pressure: 1.6 kN/m²)
10. free board: 0.2m
11. Dead storage : 0.15m
12. Total staging is 12m and has to be adjusted in last staging
13. Depth upto Raft Beam top: 1.5m
14. For detailing of reinforcement IS SP-34 shall be followed .

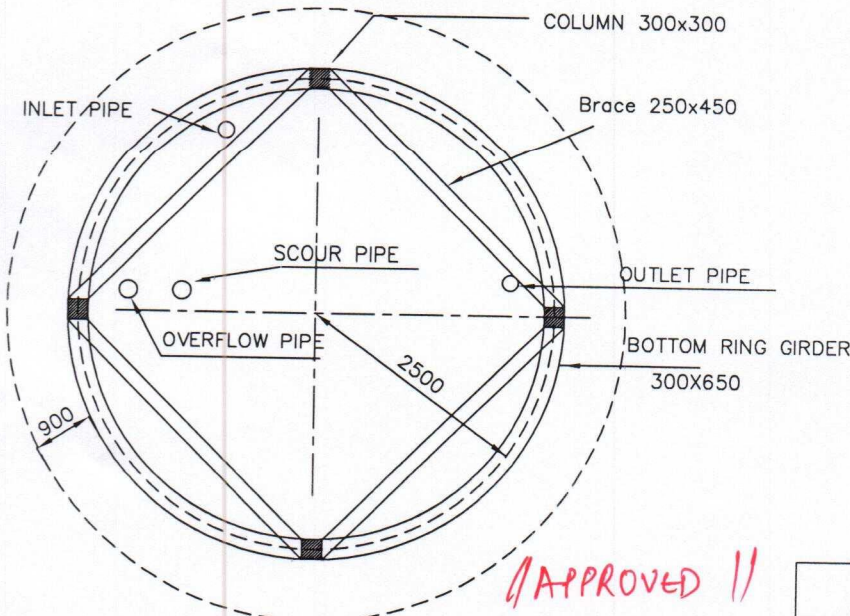

PLAN

APPROVED !!

G. V. Reddy
 CE-I CE-II CE-III
 T.P.W.S.P., Hyderabad
 11/5 11/5 11/5 11/5 11/5 11/5

Government of Telangana

Rural Water Supply & Sanitation Department

Construction of 60 KL capacity OHSR/OHBR 12m staging column type

Scale: Not to scale

sheet: 1 of 8

REV : 01

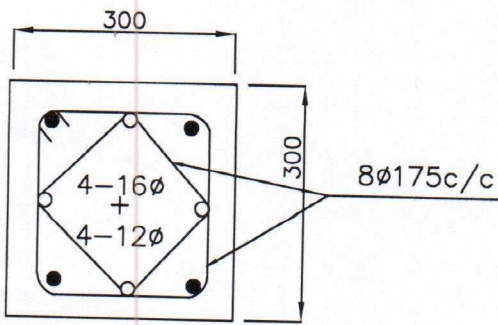

4-16 ϕ through out +
4-12 ϕ upto 1st brace

SECTION OF COLUMN

UP TO 1st BRACE

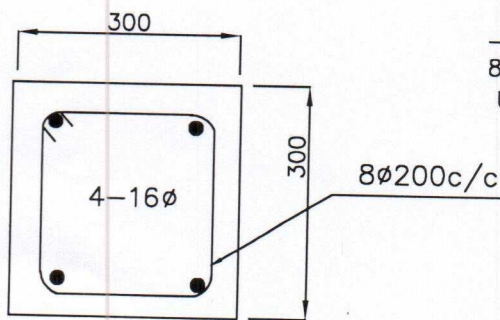

SECTION OF COLUMN

BEYOND 1st BRACE

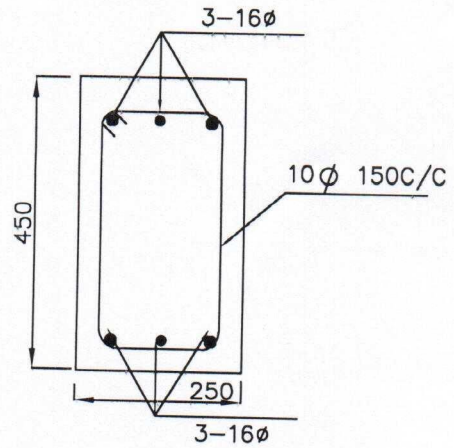

SECTION OF BRACE

NOTE: THIS DRAWING
SUPERCEDES THE
EARLIER APPROVED
DRAWING FOR 60KL
OHSR ON 17.04.2017

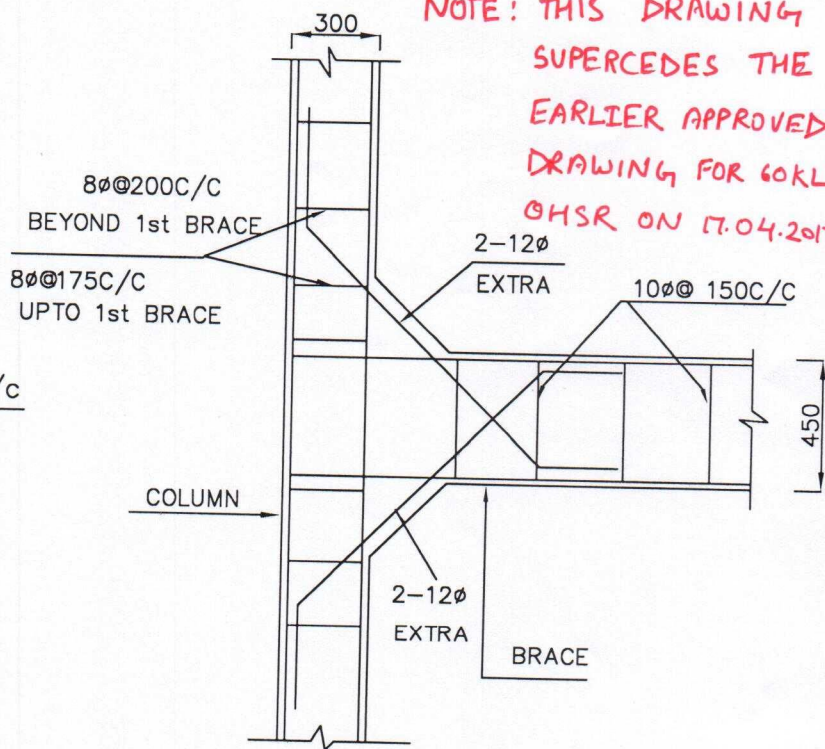

COLUMN BRACE JUNCTION

brace steel spliced at middle section only
brace rod continued at support section

GL brace is considered as plinth

" APPROVED "

CE I CE II CE III
 TDWSP, Hyderabad
 11/5 11/5 11/5/17 11/5/17 11/5/17
 Ec

Government of Telangana		
Rural Water Supply & Sanitation Department		
Construction of 60 KL capacity OHSR/OHBR 12m staging column type		
Scale: Not to scale	sheet: 2 of 8	REV: 01

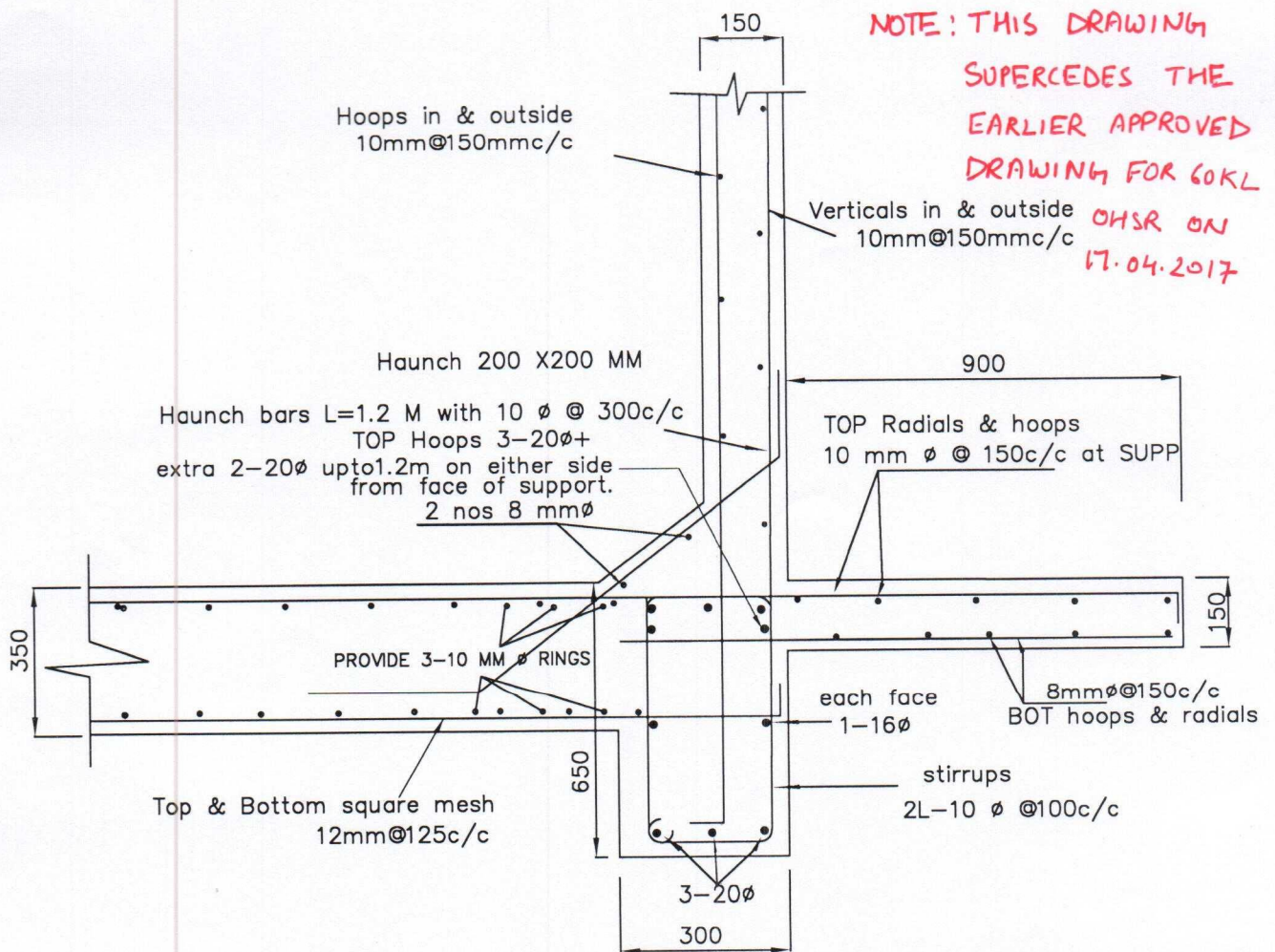
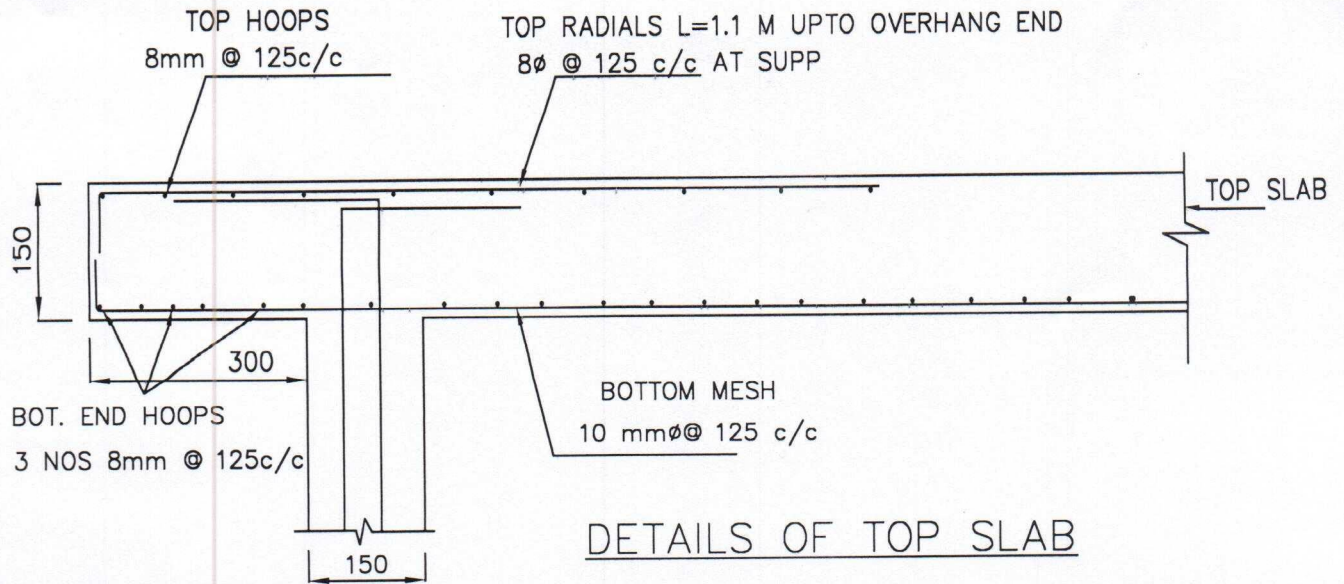

BOTTOM RING BEAM AND LANDING

// APPROVED //

CE-I
CE-II
CE-III

TDW SP, Hyderabad

11/5/17
11/5/17
11/5/17
11/5/17

Government of Telangana		
Rural Water Supply & Sanitation Department		
Construction of 60 KL capacity OHSR/OHBR 12m staging column type		
Scale: Not to scale	Sheet: 3 of 8	REV: 01

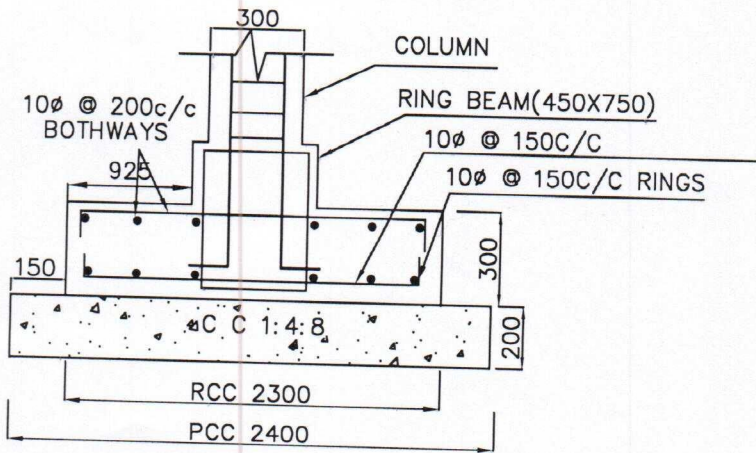

SECTION A-A

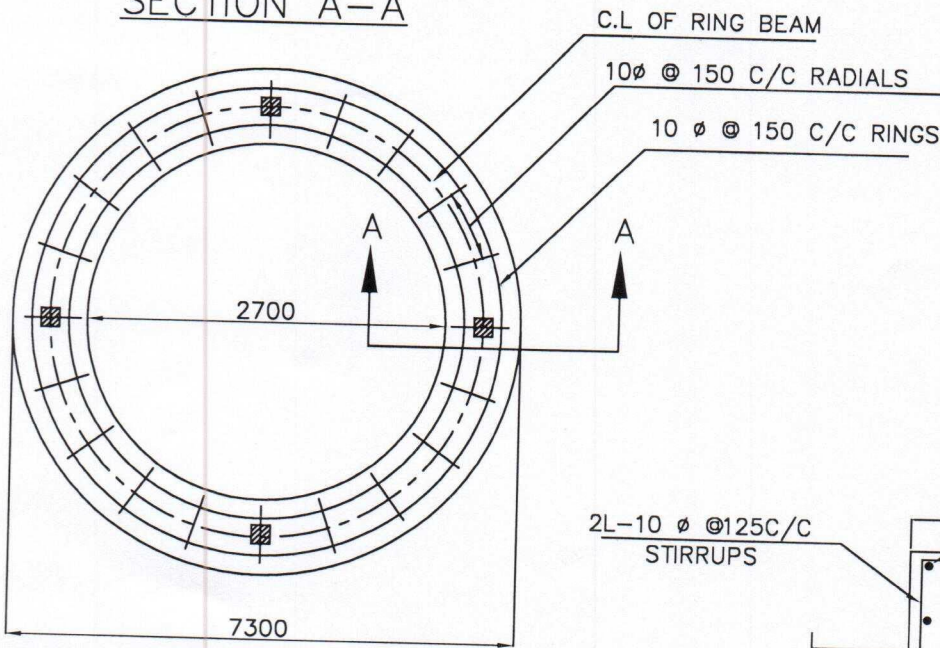

BOTTOM REINFORCEMENT OF RING FOUNDATION
SBC - 7.5t/m²

NOTE! THIS DRAWING SUPERCEDES THE EARLIER APPROVED DRAWING FOR 60KL OHSR ON 17.04.2017

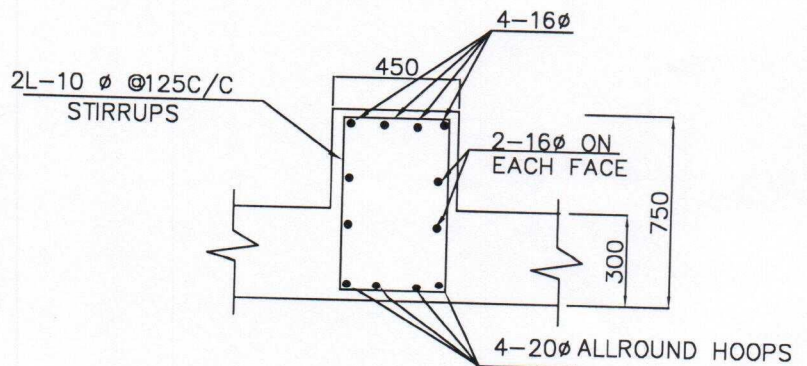

SECTION OF RING RAFT BEAM

" APPROVED "

CE I
CE II
CE III
TDWSP Hyderabad
11/5/17
11/5/17
11/5/17
11/5/17
EE

Government of Telangana		
Rural Water Supply & Sanitation Department		
Construction of 60 KL capacity OHSR/OHBR 12m staging column type		
Scale: Not to scale	sheet: 5 of 8	REV : 01

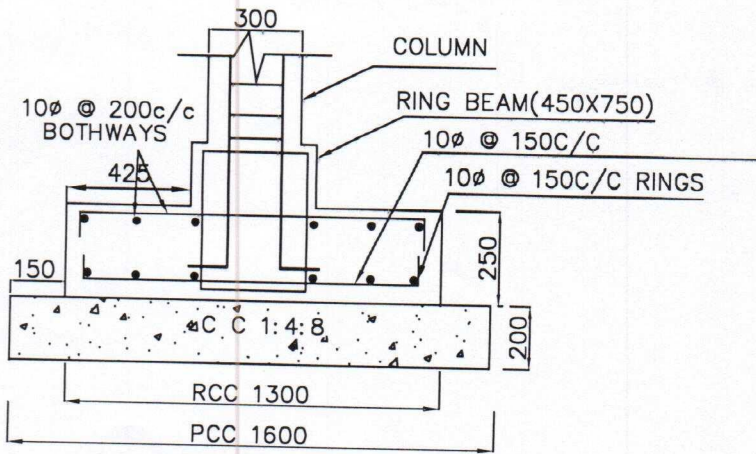

SECTION A-A

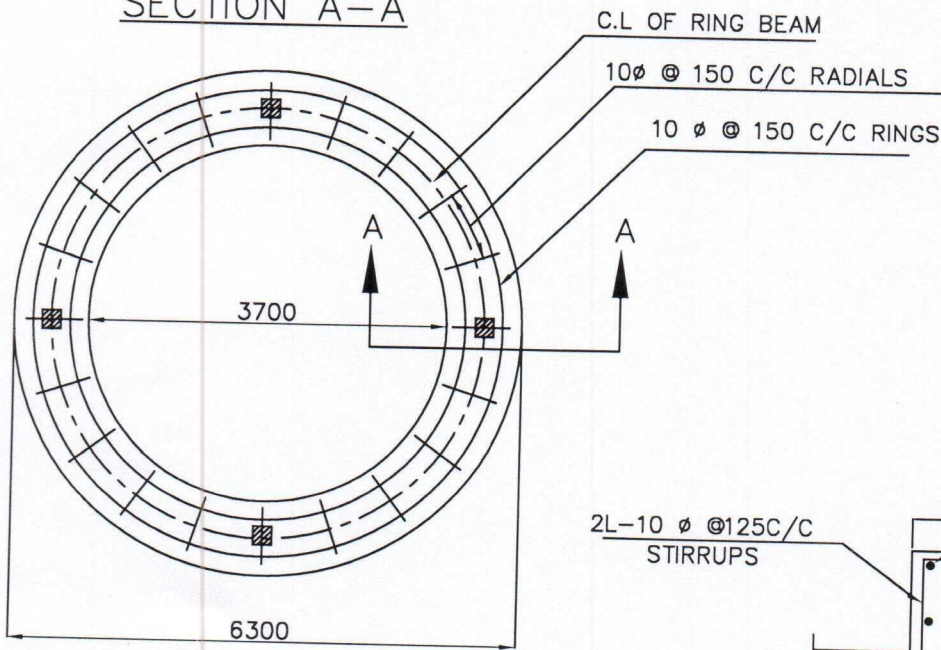

BOTTOM REINFORCEMENT OF RING FOUNDATION
SBC -15t/m²

NOTE: THIS DRAWING SUPERCEDES THE EARLIER APPROVED DRAWING FOR 60KL OHSR ON 17.04.2017

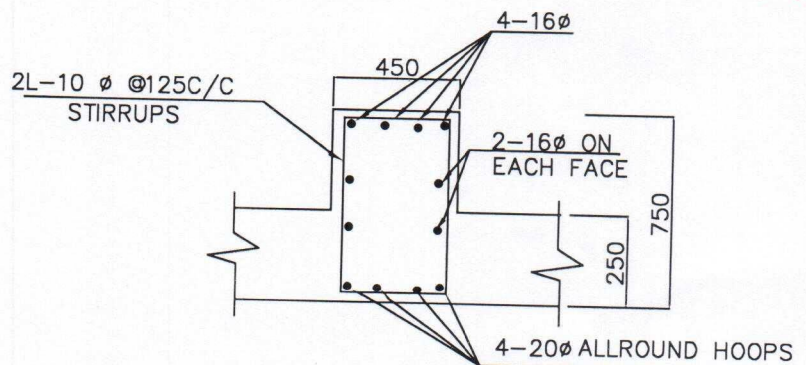

SECTION OF RING RAFT BEAM

" APPROVED "

CE I G. N. Reddy CE II CE III

 TDWSP, Hyderabad

 11/5/17 11/5/17 11/5/17 11/5/17

Government of Telangana		
Rural Water Supply & Sanitation Department		
Construction of 60 KL capacity OHSR/OHBR 12m staging column type		
Scale: Not to scale	sheet: 6 of 8	REV: 01

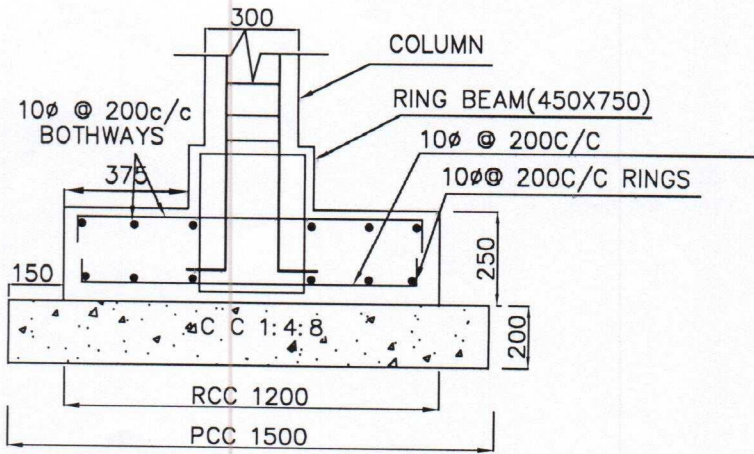

SECTION A-A

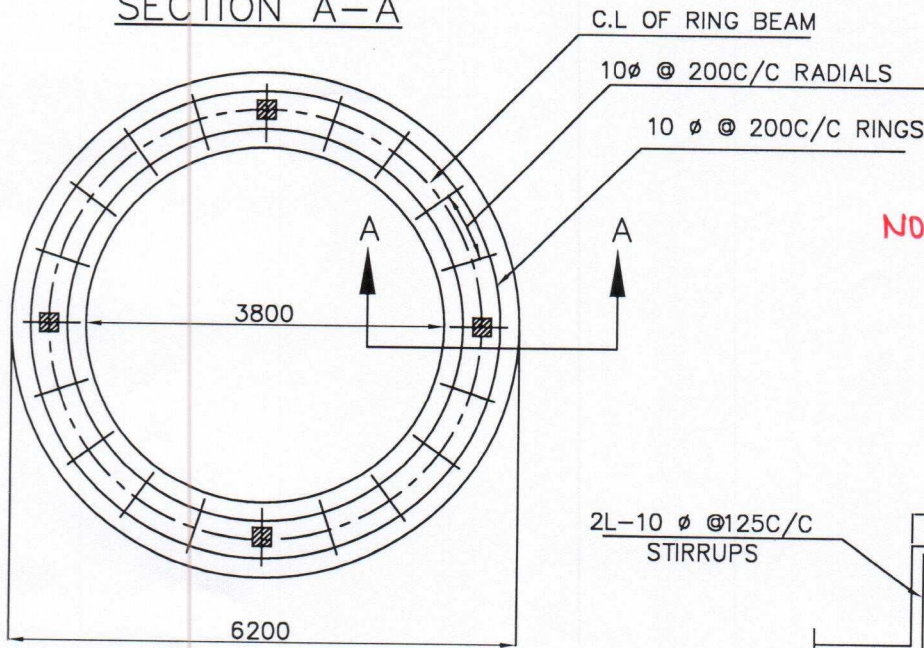

BOTTOM REINFORCEMENT OF RING FOUNDATION
SBC -20t/m²

NOTE! THIS DRAWING SUPERCEDES THE EARLIER APPROVED DRAWING FOR 60KL OHSR ON 17.04.2017

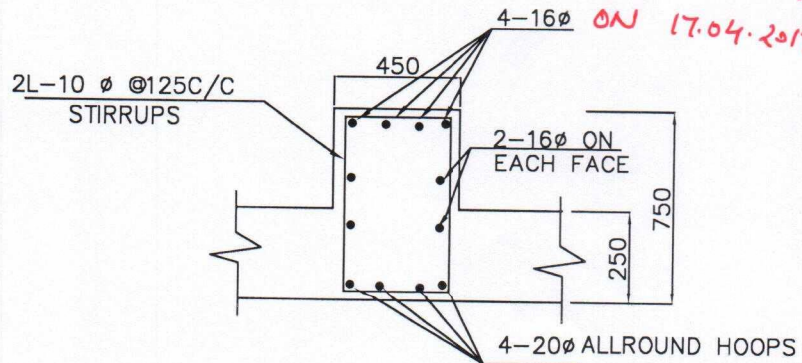

SECTION OF RING RAFT BEAM

" APPROVED "

EEI
G. Inwood
CE II
Phy
CE III
TDWSP Hyderabad
11/15
11/15
11/15/17
15/5/17
11/15/17
EE

Government of Telangana		
Rural Water Supply & Sanitation Department		
Construction of 60 KL capacity OHSR/OHBR 12m staging column type		
Scale: Not to scale	sheet: 7 of 8	REV: 01

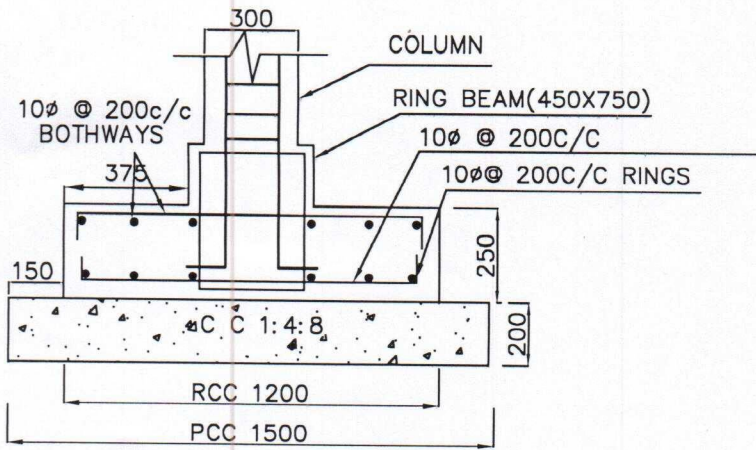

SECTION A-A

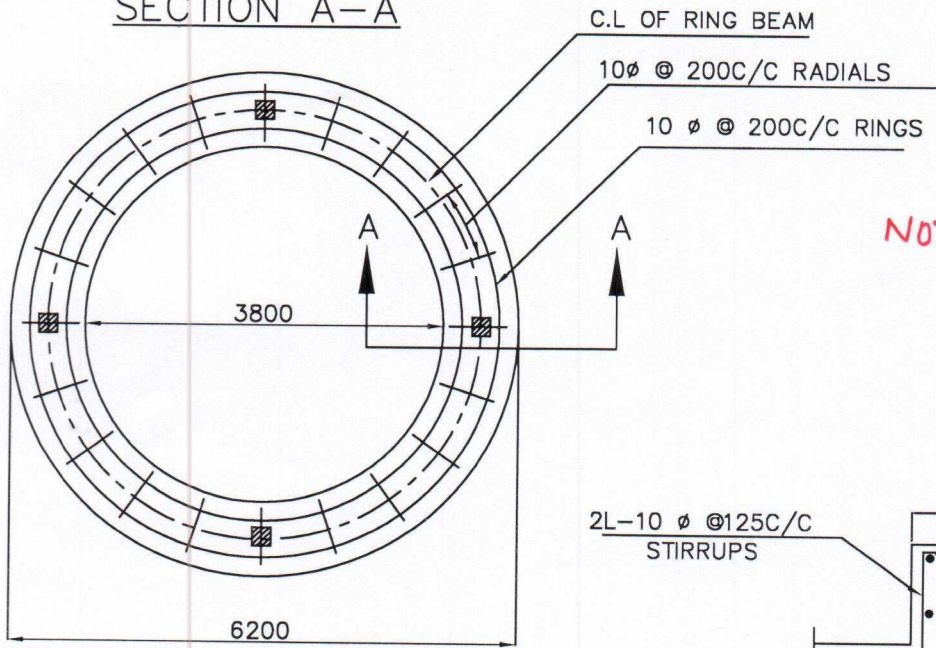

BOTTOM REINFORCEMENT OF RING FOUNDATION
SBC - 30t/m²

NOTE: THIS DRAWING SUPERCEDES THE EARLIER APPROVED DRAWING FOR 60 KL OHSR ON 17.04.2017

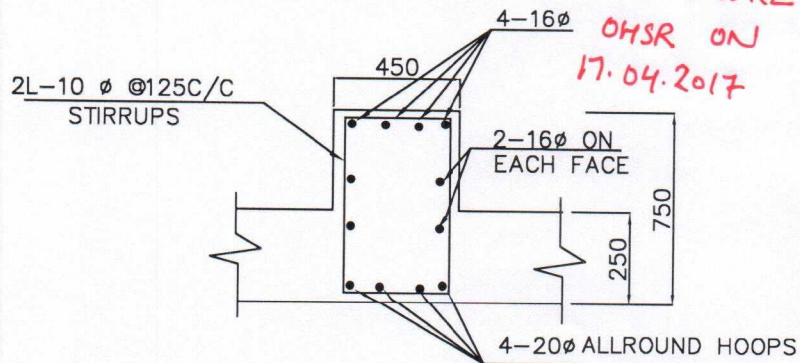

SECTION OF RING RAFT BEAM

" APPROVED "

CE I
CE II
CE III
TDWSP Hyderabad
[Signatures and dates]

Government of Telangana		
Rural Water Supply & Sanitation Department		
Construction of 60 KL capacity OHSR/OHBR 12m staging column type		
Scale: Not to scale	sheet: 8 of 8	REV : 01